

FITTING INSTRUCTION

Clamp mark in acc. with		Cables joining
ISO	PN	
1	L	Left directional lights
2	+	Rear fog lights
3	31	Ground
4	R	Right directional lights
5	58R	Right side parking lights
6	54	Stoplights
7	58L	Left side parking lights

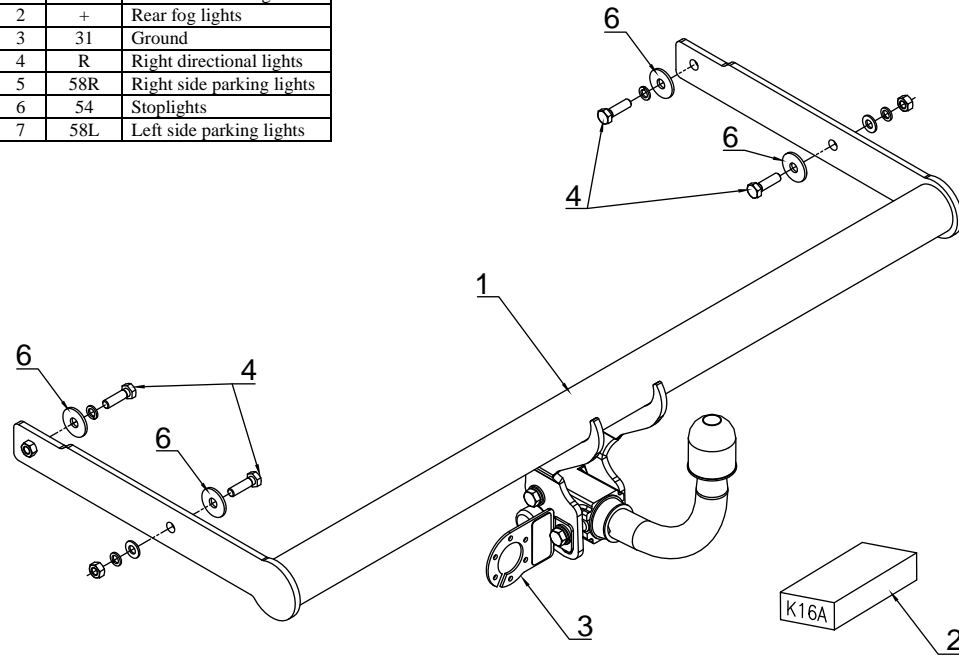

This towing hitch is designed to assembly in following cars:
VOLKSWAGEN GOLF III VARIANT, ESTATE, 4x4, produced since 10.1993 till 07.1999, catalogue number **K16A** and is prepared to tow trailers max total weight **1500 kg** and max vertical load **75 kg**.

From manufacturer

Thank you for buying our product. Their reliability has been confirmed in many tests. Reliability of towing hitch depends also on correct assembly and right operation. For this reasons we kindly ask to read carefully this instruction and apply to hints.

The towing hitch should be install in points described by a car producer.

The instruction of the assembly

1. Disassemble the bumper and then unscrew the metal fabric covers of chassis members (they not use any more).
2. Under the conservation layer, beside chassis members find fabric holes (two per each side).
3. To chassis members tunnels slide the main bar of towing hitch (pos. 1), and then fix it using bolts M10x35mm (pos. 4) with washers (pos. 6).
4. Cut the bottom part of the bumper, dimension 80x50mm.
5. Fix body of the automat and place tow-ball according to supplied instruction. Note! Remember to place socket plate (pos. 3) as shown on the drawing 1.
6. Reassemble the bumper.
7. Screw tight all bolts according to the torque shown in the table.
8. Connect the electric wires according to the instructions of the car.
9. Complete the paint cover of towbar (during assembly paint cover could be damaged).

Torque settings for nuts and bolts (8,8):

M6 - 11 Nm	M 8 - 25 Nm	M 10 - 50 Nm
M 12 - 87 Nm	M 14 - 138 Nm	M16 - 210 Nm







NOTE

After installation of a towing hitch you should get adequate note in registration book (at authorised service station). The car should be equipped with:

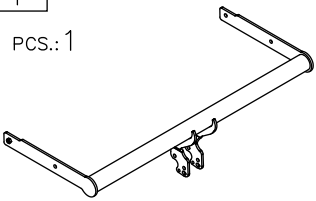
- Indicators
- Tow mirrors

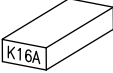
After 1000km of exploitation check all bolts and nuts. The ball of towing hitch must be always kept clear and conserve with a grease.

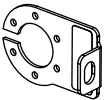
Towing hitch accessories:

Pos. 1	Main bar PCS.: 1		Pos. 5	Nut 8 B M10 PCS.: 2	
			Pos. 6	Washer ø30xø10,5x2,5mm PCS.: 4	
Pos. 2	Tow ball (mounting set) PCS.: 1		Pos. 7	Washer ø10,5mm PCS.: 2	
Pos. 3	Socket plate PCS.: 1		Pos. 8	Spring washer ø10,2mm PCS.: 4	
Pos. 4	Bolt 8.8 B M10x35mm PCS.: 4				



PPUH AUTO-HAK Sp.J.

Produkcja Zaczepów Kulowych
Henryk i Zbigniew Nejman
76-200 SŁUPSK ul. Słoneczna 16K
tel/fax +48 (59) 8-414-414; 8-414-413
E-mail: office@autohak.com.pl
www.autohak.com.pl

Towing hitch (without electrical set)

Class: **A50-X** Cat. no. **K16A**

Designed for:

Manufacturer: **VOLKSWAGEN**

Model: **GOLF III**

Type: **VARIANT, ESTATE, 4x4**

produced since 10.1993 till 07.1999

Technical data:

D-value: 7,8 kN

maximum trailer weight: **1500 kg**

maximum vertical cup load: **75 kg**

Approval number according to Directive 94/20/EC: e20*94/20*1157*00

Foreword

This towing hitch is designed according to rules of safety traffic regulations. The towing hitch is a safety component and can be installed only by qualified personnel. Any alteration or conversion of the towing hitch is prohibited and would lead to cancellation of design certification. Remove insulating compound and underseal from vehicle (if present) in the area of the mating surfaces of the towing hitch. The vehicle manufacturer's specifications regarding trailer mass and max. vertical cup mass are decisive for driving whereat values for the towing hitch cannot be exceeded.

D-value formula:

$$\frac{\text{Max trailer weight [kg]} \times \text{Max vehicle weight [kg]}}{\text{Max trailer weight [kg]} + \text{Max vehicle weight [kg]}} \times \frac{9,81}{1000} = D \text{ [kN]}$$